

Filling brake

- *Less weaving defects Increasing productivity*
 - *Cost reduction due to long life materials*
 - *Cost saving due to modular construction*
- *Straight line selvages & even fabric surfaces*
 - *Varied accessories for individual fitting*

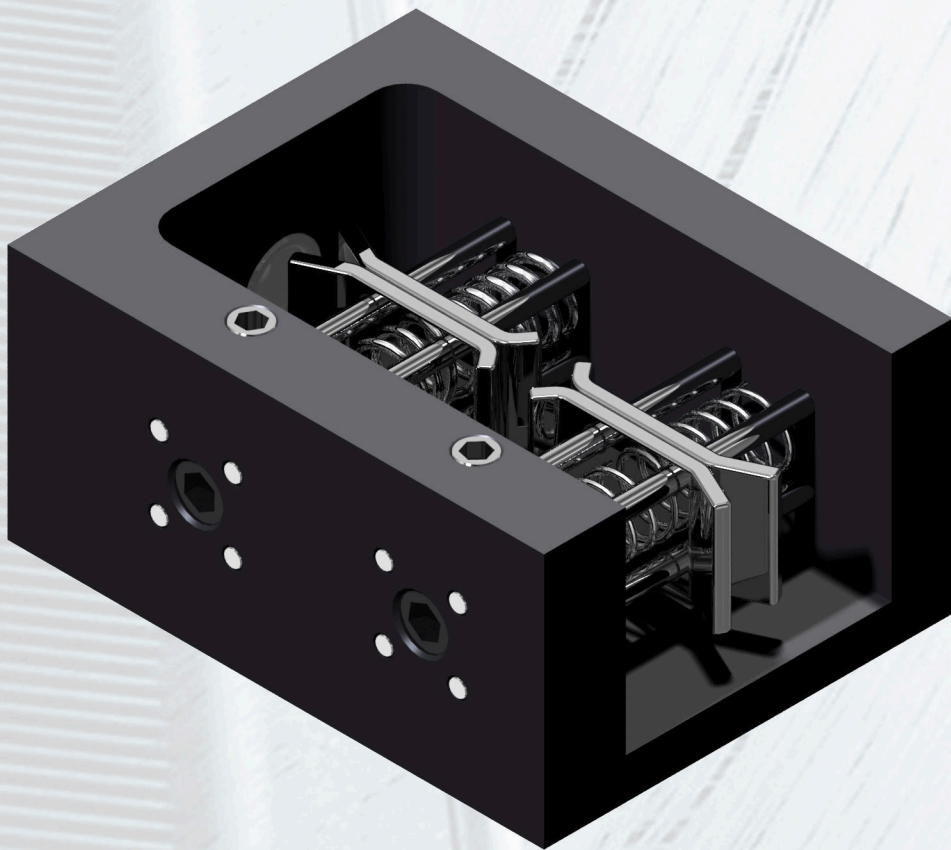

Filling brake type B

Black burnished modular filling brake "left version" with a polished ceramic eyelet with a central through hole of $\varnothing 5$ mm and 2 integrated devices for fine adjustment of the yarn tension, consisting of 2 pairs of hard chrome plated slide shoes made of spring steel. The contact surfaces of the slide shoes are even grounded, the running surfaces and radii are diamond polished. This type is equipped with one medium pressure spring type B and one strong pressure spring type C at the

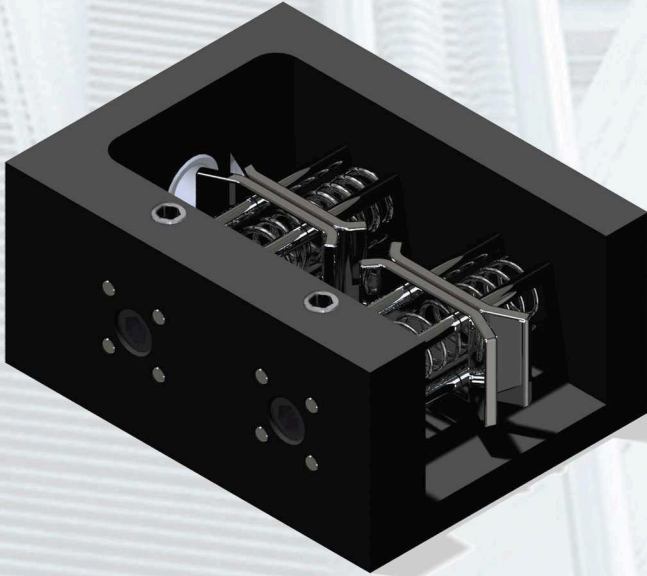

pretension area as well as at the main tension area. The pretension and the main tension could be adjusted separately and exactly.

Filling brake type C

Black burnished modular filling brake "left version" with a polished ceramic eyelet with a central through hole of $\varnothing 5$ mm and one integrated device for fine adjustment of the yarn tension, consisting of one pair of hard chrome plated slide shoes made of spring steel and 3 slide pins to string out loops. The contact surfaces of the slide shoes are even grounded, the running surfaces and radii are diamond polished. This type is equipped with one medium pressure spring type B and

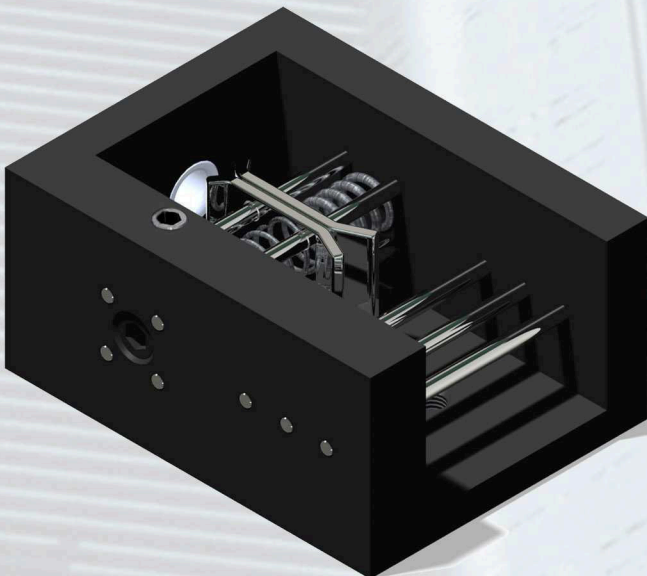

one strong pressure spring type C. This enables an exact setting of the yarn tension.

Filling brake type BR

Black burnished modular filling brake "right version" with a polished ceramic eyelet with a central through hole of $\varnothing 5$ mm and 2 integrated devices for fine adjustment of the yarn tension, consisting of 2 pairs of hard chrome plated slide shoes made of spring steel. The contact surfaces of the slide shoes are even grounded, the running surfaces and radii are diamond polished. This type is equipped with one medium pressure spring type B and one strong pressure spring type C at the

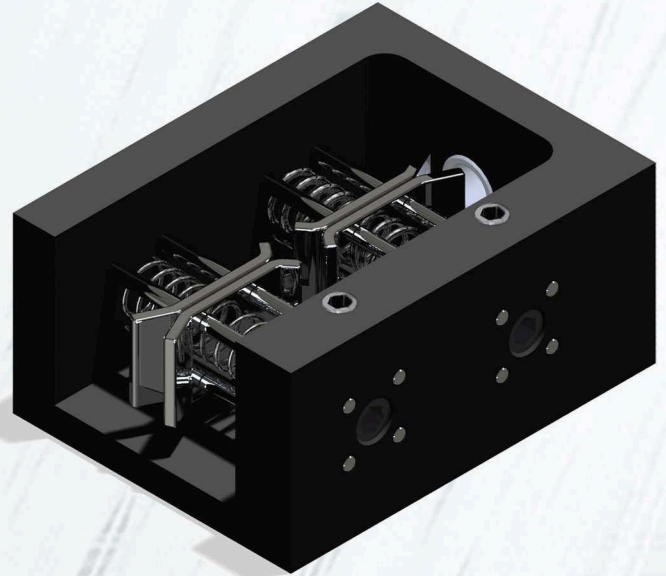

pretension area as well as at the main tension area. The pretension and the main tension could be adjusted separately and exactly.

Filling brake type MS

Black burnished modular filling brake "left version" with a polished ceramic eyelet with a central through hole of $\varnothing 8$ mm and 2 integrated devices for fine adjustment of the yarn tension, consisting of 2 pairs of hard chrome plated slide shoes made of spring steel. The contact surfaces of the slide shoes are even grounded, the running surfaces and radii are diamond polished. This type is equipped with one medium pressure spring type B and one strong pressure spring type C at the

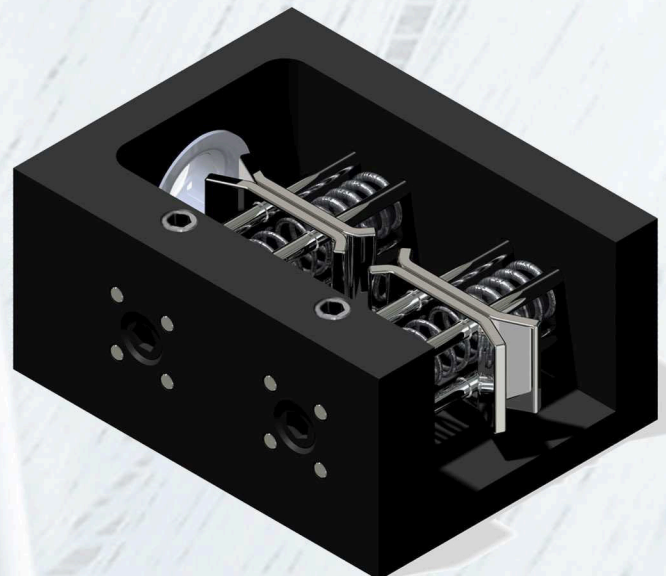

pretension area as well as at the main tension area. The pretension and the main tension could be adjusted separately and exactly. Especially for yarns with a diameter between 2,0 and 5,0 mm .

Standard: Slide shoes type HC

Hard chrome plated pair of slide shoes with a minimum thickness of the hard chrome coating layer of 20 µm. Polished design with fine surface finish: Ra 0.5 µm. Hardness according to Vickers: HV = 1200.



Application area slide shoes

Slide shoes type HC, HCS, Ceramics, KK & KB are compatible with the filling brakes type B, BR, C & MS. These ones can be used customer-specific, related to the operational area.



Option: Ceramics slide shoes

Ceramics slide shoes made from Al₂O₃ 99%. The contact surfaces of the slide shoes are even grounded and the running surfaces and radii are diamond polished. Temperature resistance: 1.750 °C, Hardness: 1.800 HV

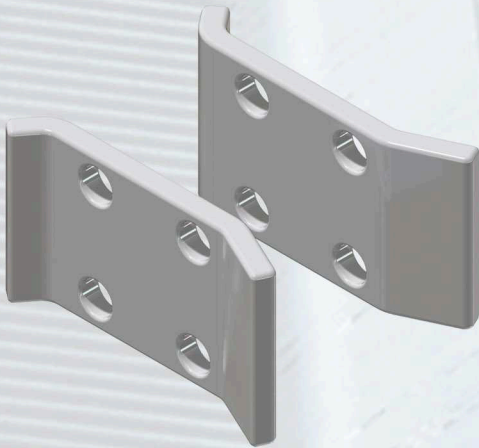

It is not advisable to mix slide shoes with different coatings within one pair of slide shoes. The combination of different coatings within one pair of slide shoes can cause damages at the surfaces of the shoes and yarns.

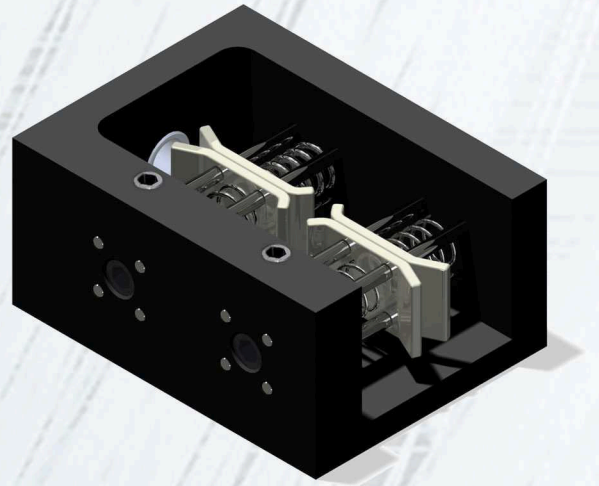

Option: Slide shoes type HCS

Hard chrome plated pair of slide shoes with a minimum thickness of the hard chrome coating layer of 70 µm. Polished design with fine surface finish: Ra 0.5 µm. Hardness according to Vickers HV = 1200.

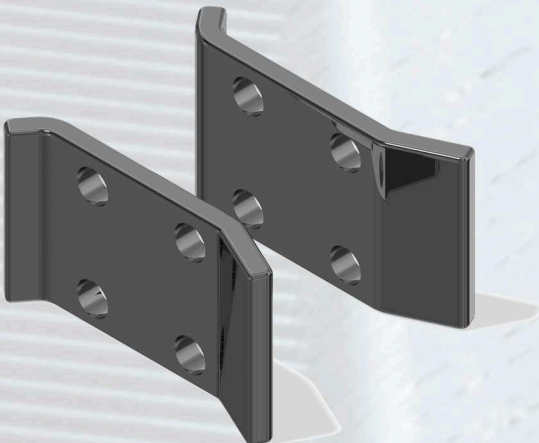

Option: Slide Shoes type KB

Hard chrome plated pair of slide shoes with a minimum thickness of the hard chrome coating layer of 70 µm. Polished design with fine surface finish: Ra 0.5 µm. Hardness according to Vickers HV = 1200.

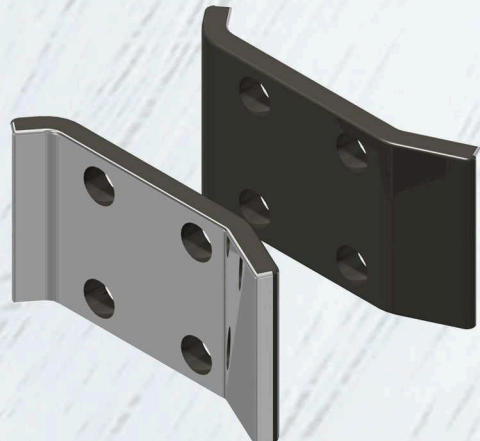

Option: Slide shoes type KK

Hard chrome plated pair of "Knot-Killer" slide shoes with a minimum thickness of the hard chrome coating layer of 20 µm. Polished design with fine surface finish: Ra 0.5 µm. Hardness according to Vickers: HV = 1200.



The special inlet area of the slide shoes, with a very fine bevel, ensures a smooth filling running and blocks nearly every knot or loop.



Filling brake Type BR with slide shoes type KK

A further variant of the filling brake type BR "right version" is the type BRK, equipped with one pair "Knot-Killer" slide shoes KK, which blocks nearly every knot or loop and activates at the same time the yarn cutter.

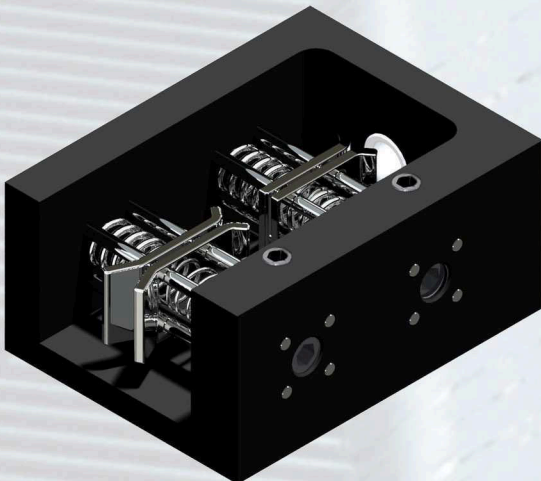

Filling brake type B with slide shoes KK

A further variant of the filling brake type B "left version" is the type BK, equipped with one pair "Knot-Killer" slide shoes KK, which blocks nearly every knot or loop and activates at the same time the yarn cutter.

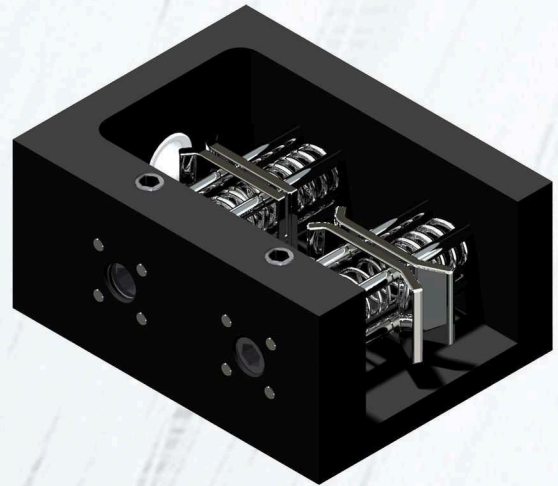

This type is equipped with one weak pressure spring type A and one strong pressure spring type C at the pretension area and two strong pressure springs type C at the main tension area. The pretension and the main tension could be adjusted separately and exactly.

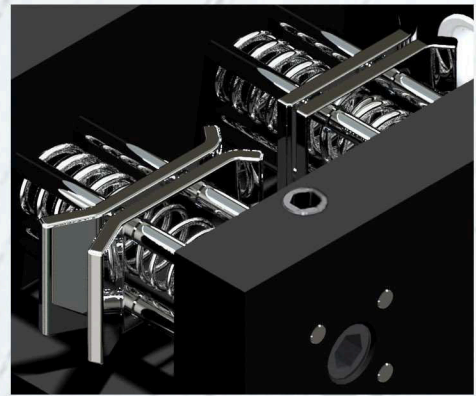

Slide shoes type KK in combination with type HC

The slide shoes type KK are by default used in combination with hard chrome plated pairs of slide shoes type HC with a minimum thickness of the hard chrome coating layer of 20 µm.

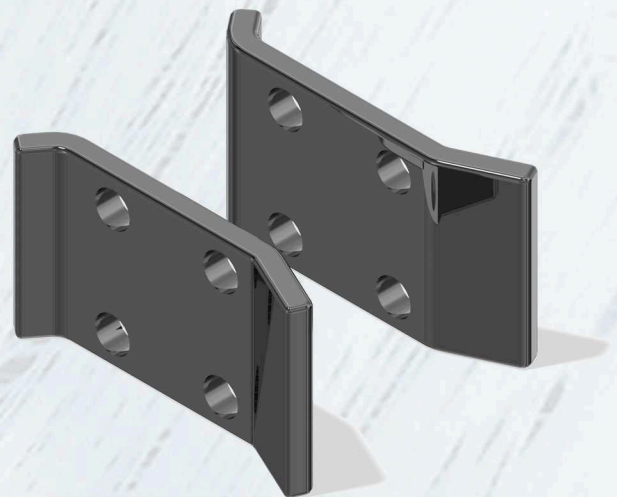

Filling brake type BCE

Modular filling brake "left version" with 2 polished ceramic eyelets (central through (hole \varnothing 2 mm) and 2 integrated devices for fine adjustment of the yarn tension, consisting of 2 pairs of hard chrome plated slide shoes type HC. The fastening of the brake occurs through 2 internal M4 threads.

Application: Yarn tension adjustment at rigid monofilament fibers with a high abrasion tendency.

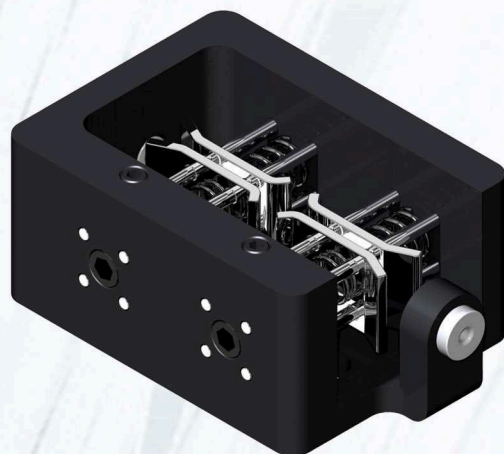

Different pressure springs

Different spring combinations make this filling brake universally applicable at a wide range of different materials. This possibility allows the user to equip the brakes to the requirements of the production process.

Pressure spring type A

Pressure spring type A "weak version", made of stainless steel for setting the initial yarn tension.

Spring force: $F_n = 11.7 \text{ N}$

Pressure spring type B

Pressure spring type B "medium version", made of stainless steel for setting the initial yarn tension.

Spring force: $F_n = 26.5 \text{ N}$

Pressure spring type C

Pressure spring type C "strong version", made of stainless steel for setting the initial yarn tension.

Spring force: $F_n = 57.4 \text{ N}$

Pressure spring type E

Pressure spring type E "very strong version", made of stainless steel for setting the initial yarn tension.

Spring force: $F_n = 64.8 \text{ N}$

Application area pressure springs type A, B & C

This stainless steel pressure springs are designed to be used at filling brakes type B, BR, C & MS.

Application area pressure spring type E

This stainless steel pressure spring is designed to be used at filling brake type MS.



Filling brake type KAS

Black burnished modular filling brake "left version" with a polished ceramic eyelet with a central through hole of $\varnothing 8$ mm and 2 integrated devices for fine adjustment of the yarn tension, consisting of 2 pairs of hard chrome plated slide shoes made of spring steel. The contact

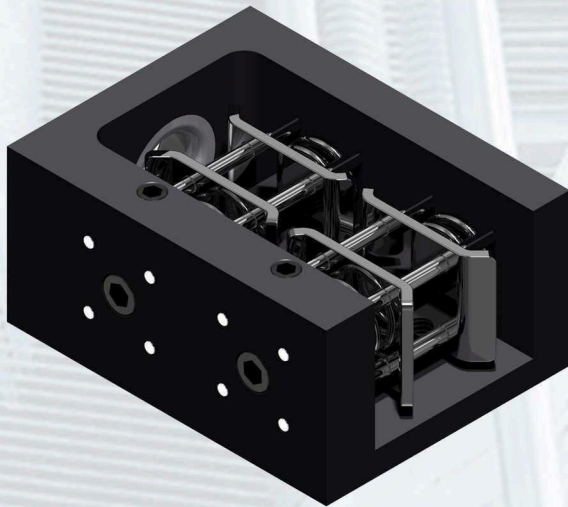

surfaces of the slide shoes are even grounded, the running surfaces and radii are diamond polished. Particularly suitable for very thick yarns as used at the production of fibre cement felts. This type is equipped with one medium pressure spring type BK and one strong pressure spring type CK at the pretension area as well as at the main tension area.

Pressure spring type BK

Pressure spring type BK "medium version" made of stainless steel for setting the initial yarn tension. Length: 7,9 mm. Spring force: 29 N

Pressure spring type CK

Pressure spring type CK "strong version" made of stainless steel for setting the initial yarn tension. Length: 6,3 mm. Spring force: 29 N

Application area pressure springs type BK & CK

Stainless steel pressure springs type BK and type CK are designed to be used at filling brakes type KAS.

Standard: Slide shoes type KAS

Hard chrome plated pair of slide shoes with a minimum thickness of the hard chrome coating layer of $20 \mu\text{m}$. Polished design with fine surface finish: $Ra 0.5 \mu\text{m}$. Hardness according to Vickers: $HV = 1200$.

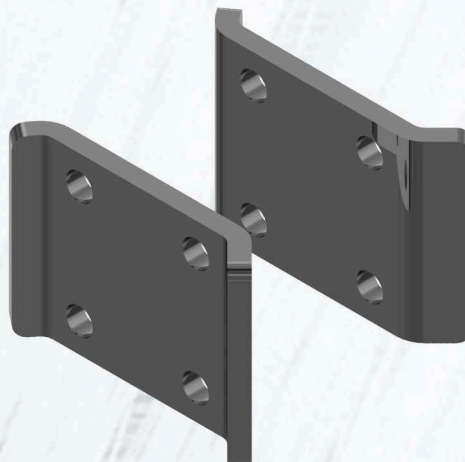

At the filling brake type KAS the pretension and the main tension could be adjusted separately and exactly. This ensures straight line selvages and an even fabric surfaces.



MARIN
Industrietechnik

Lechstrasse 2
73529 Schwaebisch Gmuend
Germany

fon: + 49 (0) 7171 98 90 52
fax: + 49 (0) 7171 98 90 53

email: info@marin-technik.de
home: www.marin-technik.de